

POWER ROOF VENTILATORS

ILG Model CRDA - Direct Drive

ILG Direct Drive Power Roof Ventilator has spun aluminum cover designed for high wind locations. Fan Performance Ratings are AMCA Certified for Air and Sound and are U.L. Listed. All motors are 115 volt, single phase.

Construction

- ILG "C Drive" bearings shall have a calculated L10 bearing life in excess of 1,000,000 hrs
- Factory mounted motor and drive with pre-set fan RPM.
- Spun and shaped aluminum construction.
- Positively ventilated motor compartment with motor out of the air stream.
- Vibration-Free Polypropylene Mesh Birdscreen.

Motors and Electrical

- U.L. 705 Listing.
- Integral motor thermal overload protection on all standard single phase motors.
- Safety disconnect.

Drive Components

- Variable pitch, cast iron drives, with oil resistant, non-static V-belts.

Impeller

- Spark-resistant construction (AMCA Type "C")

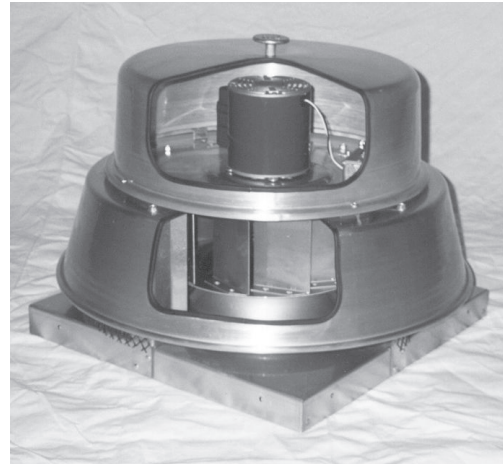

Model	HP	RPM	CFM @ Listed Static Pressure				Max. Sones	Price Each	Gravity Damper BDDH	Roof Curb CPC-3
			0"	.25"	.50"	.75"				
CRDA 06	1/10	775-1650	542	459	360	-	9.8	\$298	\$37	\$58
CRDA 08	1/10	775-1600	696	611	529	373	10.4	312		
CRDA 10	1/10	825-1550	903	801	674	459	9.7	325		
CRDA 12	1/8	570-1050	1188	1014	792	-	7.4	484	\$48	\$71
CRDA 13	1/5	570-1140	1735	1555	1356	-	10.3	494		
CRDA 15	1/3	570-1140	2288	2177	2016	1813	13.3	535		

Notes:

- 1) Model SC72W Speed control may be used for up to 50% speed reduction. Price each is \$31.
- 2) See page 26 for roof curbs.

Model	Ventilator Dimension			Roof Curb and Damper Dimension				Unit Weight
	Inside Curb-Cap A	Unit DIA. B	Unit Height C	BDD Damper Size E	Roof Opening G	Curb O.D. H		
CRDA 06, 08, 10	18	10 7/8	12	12 1/2	11 1/4	16 1/2	35	
CRDA 12, 13, 15	23	28 5/8	22 1/2	17 1/2	16 1/4	21 1/2	85	

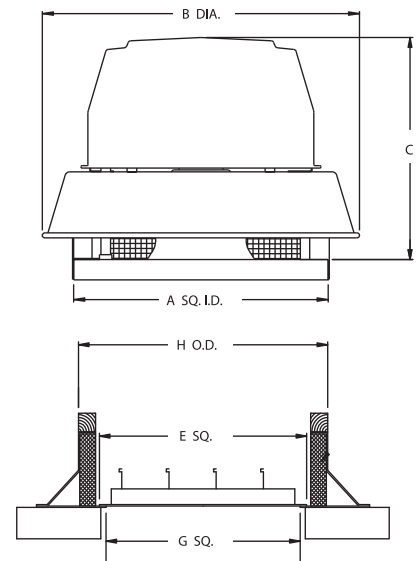

L. R. GORRELL COMPANY

PRICES SUBJECT TO CHANGE WITHOUT NOTICE! Minimum Order is \$35.00